

RUN WITH RAM TRAILER



GENERAL CARGO GROUP

GENERAL CARGO SEMI TRAILER
30 TON - 2 AXLE



TECHNICAL SPECIFICATION

GENERAL CARGO SEMI TRAILER

30 TON - 2 AXLE

Dimensions and Charges (Compulsory)

Overall width	2550mm	Total Payload (capacity)	>= 30.000kg
Platform length	40 feet	Max speed at full load	85 km/h

Dimensions and Charges (Limited flexibility might be allowed)

Distance between axles	1380 mm	Axle Group Capacity	28 000 kg
Overall length	12685 mm	King Pin Capacity	18 000 kg
Loading platform height	1668,5 mm	Total GCW (Capacity)	46 000 kg
Fifth wheel height		Empty weight of trailer	8000 kg
Gooseneck length			

King Pin

3.5½-inch and 2-inch interchangeable fifth wheel king pins compliant with SAE R55.01
Both king pins will be put in toolbox.

Chassis Construction

SERIN chassis suitable for 98/91 EEC standards made from S355 or superior steel with "I" profile shape, produced with atomized submerged arc welding system. The two steel rails will be strongly connected by U-shaped crossbeams.

Platform

The floor, the back and the exterior body of the platform will be made with hard and thick (4mm) checkered steel.

The platform is equipped with the necessary eight twist locks for one or two containers of 20' or one of 40'. These twist locks are fixed on the tray.

Side Walls

600 mm side walls, made of 2MM ST37 steel, can be opened and dismantled.

Brake system

The brake system is suitable for 71/320 EC and 2002/78 EC standards. It will respect the EU norm ECE R10.03 on electromagnetic emissions.

The brake system includes a parking brake, a safety brake, an automatic setting of play system

The brake system includes an ABS (anti-lock brake system) or EBS.

Double compressed air line (yellow and red) connected to the tractor

Axles

2 axles. SERIN Brand high steel resistance 14 ton capacity each.

Mechanical suspension with blades

Compliant with ECE R.13.11

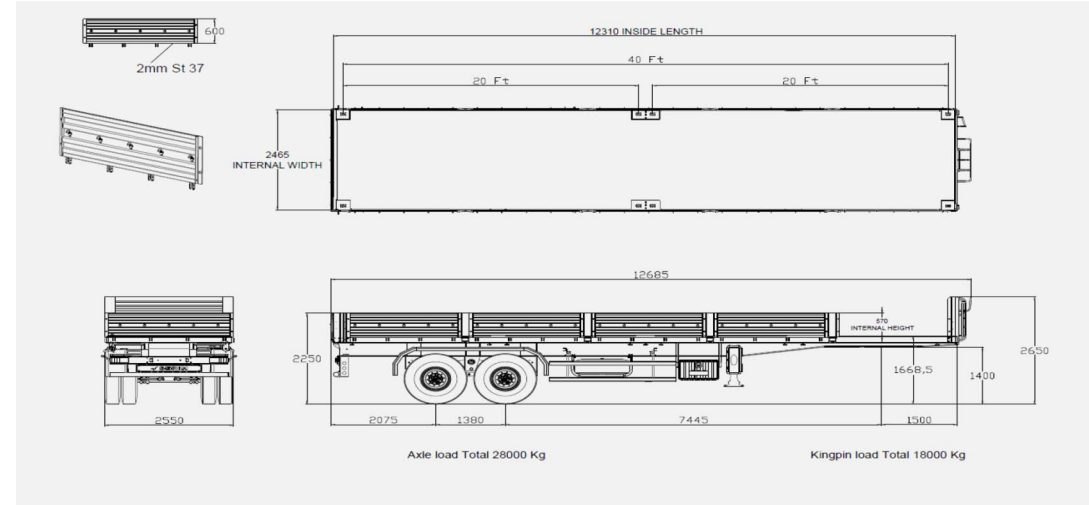

RAM İTHALAT İHRACAT İNŞAAT NAKLİYAT SANAYİ VE TİCARET LİMİTED ŞİRKETİ

Fevzi Çakmak Mahallesi 10753. Sokak KOBİSAN-2 No: 42G Karatay / KONYA

www.ramtreyler.com

info@ramtreyler.com

[ramtreyler](https://www.facebook.com/ramtreyler)

+90 552 642 12 84

+255 752 914 241

Tanzania Service and Spare Parts Sales Point



RAM TREYLER, reserves the right of making changes in the technical specifications and components without making any prior notice. Some components seen on the photographs and specifications seen here may not be standard features of the vehicles. There may have been some changes after publication of this document. No right can be claimed on a sign or numbers used by seller or buyer to define a product on ordering. Differences in colors are due to printing techniques.



TSEK

