

MAPA DETAYI

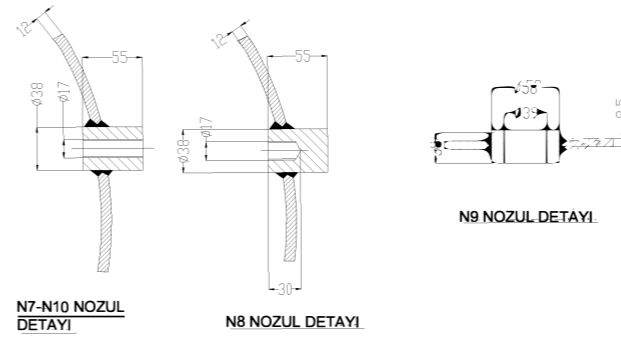

N9 NOZUL DETAYI

N7-N10 NOZUL DETAYI

N8 NOZUL DETAYI

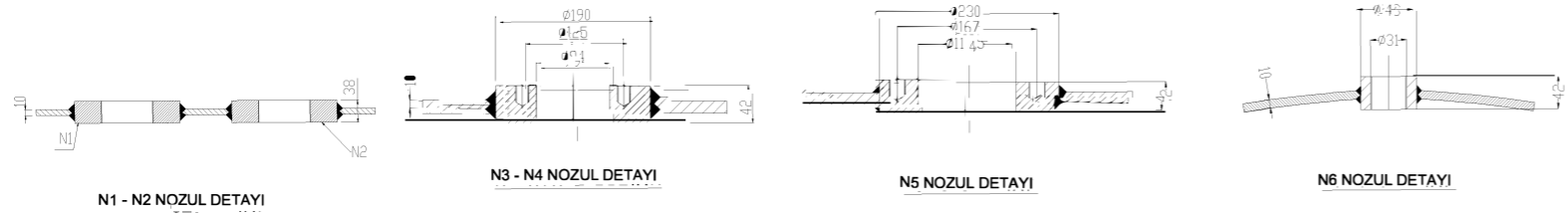

N1 - N2 NOZUL DETAYI

N3 - N4 NOZUL DETAYI

N5 NOZUL DETAYI

N6 NOZUL DETAYI

Dizayn Kodu	/ 3070
Geometrik Hacim	52 000 lt
Dizayn Basıncı	17,5 BAR
Dizayn Sıcaklığı	-20°C/+50°C
Tank Malzemesi	P355GH
Gövde Kalınlığı	10mm
Bombe Kalınlığı	12mm
Test Basıncı	26,5 BAR
Kaynak Faktörü	1
RT (Gövde - Bombe)	%25
VT (Gövde - Bombe - Nozullar)	%100
Isıl İşlem	Bombe

POS	MİKTAR	AÇIKLAMA	MALZEME	NOT
N1	1	2"Emniyet Ventili Manşonu		-
N2	1	2"Emniyet Ventili Manşonu		-
N3	1	2" Blok Flanş		-
N4	1	2" Blok Flanş		-
N5	1	3" Blok Flanş		-
N6	1	Rotageç Manşonu		-
N7	1	Manometre Manşonu		-
N8	1	Termometre-Manşonu		-
N9	1	Acil Çıkış Manşonu		-
N10	1	Rochester Manşonu		-
M1	1	Menhol İç Flanşı		-
M2	1	Menhol Dış Flanşı		-

TANIM / DESCRIPTION

52 m³ LPG Transport Tank

TARİH	İMZA	İŞ NO	T0054LX1
		RESİM NO	1
		DRAWING NO	