

RUN WITH RAM TRAILER



LPG GROUP

50 M3 LPG SEMI TRAILER



1. 50 m³ LPG TRANSPORT TANK TECHNICAL DETAILS:

TANK TYPE	Horizontal Cylindrical
PROJECT CODE	AD- Merkblatter / EN 13450
DESIGN TEMPERATURE	Min -20°C / max +70°C
DESIGN PRESSURE	17,5 bar
TEST PRESSURE	26,5 bar
MATERIAL	P355 GH or P355NH
HEAD TYPE	Elipsoidal
EXTERNAL TANK DIAMETER	50 m3 2.400 mm
BODY TANK THICKNESS	50 m3 10 mm
HEAD TANK THICKNESS	50 m3 12 mm
TOTAL LENGTH OF TANK	50 m3 11.200 mm
CORROSION	1 mm
TANK VOLUME	50 m3
EQUIPMENT TANKS OVER	Hydraulic Operator 1 unit 2 "Ball Valves 2 units BATU 2" Hydraulic valves 1 units ATILIM 3" Hydraulic valves 1 units ATILIM 2 "Safety Valve 2 units ATILIM Rotogauge (Rotary Level Indicator) 1 unit ATILIM Glycerine pressure gauge (0-25 bar), Ø 63 1 unit PAKKENS Thermometer (-30 / 60 ° C) Ø63 1 unit PAKKENS Acme Filler Cap 2 units ATILIM Manhole 1 unit 16" Filter 1 unit
Blasting and Painting	Before painting, the Tank will be sand blasted with SA 2.5 quality undercoat & polyurethane based white topcoat applied providing a total thickness of min. 150 microns. COLOUR: WHITE
Control (Inspection and Tests)	All tests & inspections mentioned below will be carried out under the control of third party & certified by the same authority. Checking & approval of design & calculations, Material inspection & stamp transferring seperately, Visual & dimensional inspection plate orientation, Head control, Radiographic control, Penetrate dye test, Hydrostatic test The reports of the A/M tests & inspections will be presented to the customer together with the inspection certificate of teh tank which will be given by the third party after the completion of the tank & the inspections.
CERTIFICATION	ISO 9001-2008 VE EN 3834-2

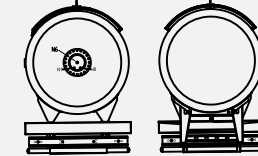
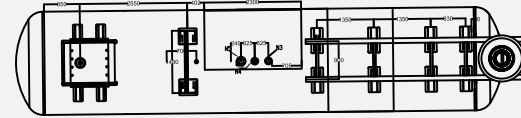
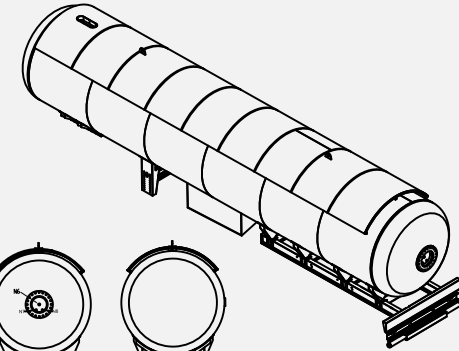
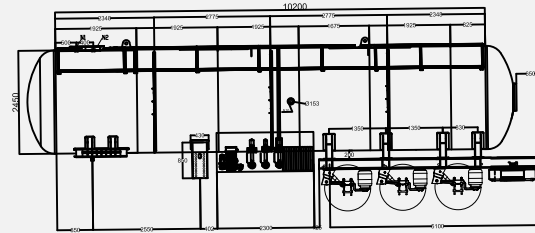

RAM İTHALAT İHRACAT İNŞAAT NAKLİYAT SANAYİ VE TİCARET LİMİTED ŞİRKETİ

ADRES : Fevzi Çakmak mah. 10753 sok. KOBİSAN-2 No:42G Karatay / KONYA

www.ramtreyler.com

info@ramtreyler.com

[ramtreyler](https://www.facebook.com/ramtreyler)

+90 552 642 12 84

+255 752 914 241

Tanzania Service and Spare Parts Sales Point



RAM TREYLER , reserves the right of making changes in the technical specifications and components without making any prior notice. Some components seen on the photographs and specifications seen here may not be standard features of the vehicles. There may have been some changes after publication of this document. No right can be claimed on a sign or numbers used by seller or buyer to define a product on ordering. Differences in colors are due to printing techniques.



TSEK

