



LPG GROUP

45 M3 SINGLE TIRES LPG SEMI TRAILER



45 m³ LPG TRANSPORT TANK TECHNICAL DETAILS:

BRAND	RAM
TANKTYPE	Horizontal Cylindrical
PROJECT CODE	AD- Merkblatter / EN 13445
DESIGN TEMPERATURE	Min -20 °C / max+70 °C
DESIGN PRESSURE	17,5 bar
TEST PRESSURE	26,5 bar
MATERIAL	P355 GH or P355NH
HEADTYPE	Elipsoidal
EXTERNAL TANK DIAMETER	45 m3 2.400 mm
BODY TANK THICKNESS	45 m3 10 mm
HEAD TANK THICKNESS	45 m3 12 mm
TOTAL LENGTH OF TANK	45 m3 11.200 mm
CORROSION	1 m m
PUMP	CORKEN PUMP
TANKVOLUME	45 m3
EQUIPMENT TANKS OVER	Hydraulic Operator 1 unit 2 "Ball Valves 2 units BATU 2" Hydraulic valves 1 units ATILIM 3" Hydraulic valves 1 unit ATILIM 2 "Safety Valve 2 units ATILIM Rotogauge (Rotary Level Indicator) 1 unit ATILIM Glycerine pressure gauge (0-25 bar), M 63 1 unit PAKKENS Thermometer (-30 / 60 ° C) M163 1 unit PAKKENS Acme Filler Cap 2 units ATILIM Manhole 1 unit 16" Fiter 1 unit
Blasting and Painting	Before painting, the Tank will be sand blasted with SA 2.5 quality undercoat & polyurethane based white topcoat applied providing a total thickness of min. 150 microns. COLOUR: WHITE
Control (Inspection and Tests)	All tests & inspections mentioned below will be carried out under the control of third party & certified by the same authority. Checking & approval of design & calculations, Material inspection & stamp transferring separately, Visual & dimensional inspection plate orientation, Head control, Radiographic control, Penetrate dye test, Hydrostatic test The reports of the A/M tests & inspections will be presented to the customer together with the inspection certificate of the tank which will be given by the third party after the completion of the tank & the inspections. BUREAU VERITAS
CERTIFICATION	isa 9001-2008 VE EN 3834-2

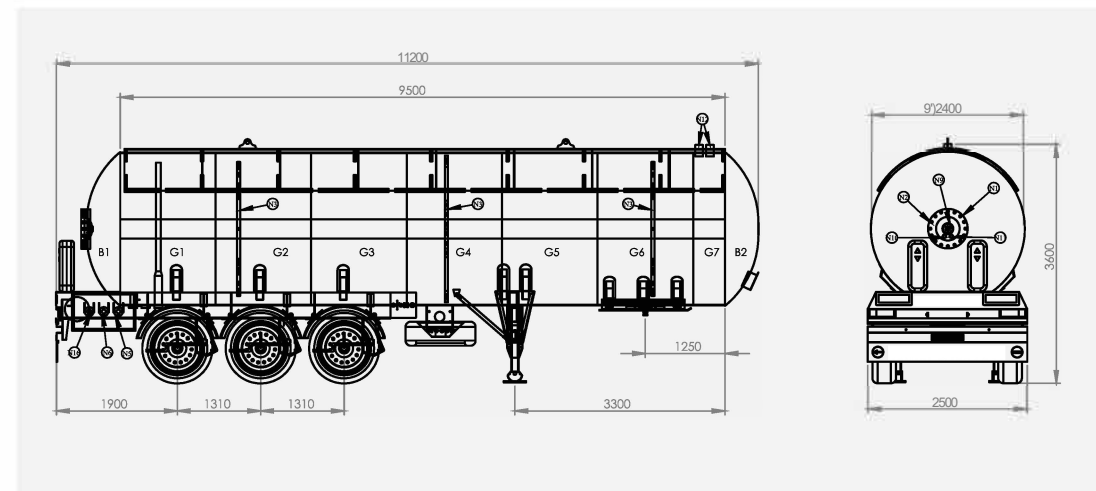

RAM İTHALAT İHRACAT İNŞAAT NAKLİYAT SANAYİ VE TİCARET LİMİTED ŞİRKETİ

Konya Organize Sanayi Bölgesi Gönülveren Sok No: 20/5 Selçuklu/ KONYA

(ff) www.ramtreyler.com

(9) info@ramtreyler.com

(f) @ ramtreyler

+90 552 642 12 84

+255 752 914 241

Tanzania Service and Spare Parts Sales Point



RAM TREYLER reserves the right of making changes in the technical specifications and components without making any prior notice. Some components seen on the photographs and specifications seen here may not be standard features of the vehicles. There may have been some changes after publication of this document. No right can be claimed on a sign or numbers used by seller or buyer to define a product on ordering. Differences in colors are due to printing techniques.



TSEK

